

ILE D'ESPRIT — KHA SHING



Builder: KHA SHING

Year Built: 1998

Model: Motor Yacht

Price: PRICE ON APPLICATION

Location: United Kingdom

LOA: 59' 4" (18.08m)

Beam: 15' 0" (4.57m)

Min Draft: 5' 4" (1.63m)

Cruise Speed: 14 Kts. (16 MPH)

Max Speed: 18 Kts. (21 MPH)

Our experienced yacht broker, Andrey Shestakov, will help you choose and buy a yacht that best suits your needs ILE D'ESPRIT — KHA SHING from our catalogue. Presently, at Shestakov Yacht Sales Inc., we have a wide variety of yachts available on our sale's list. We also work in close contact with all the big yacht manufacturers from all over the world.

If you would like to buy a yacht ILE D'ESPRIT — KHA SHING or would like help answering any questions concerning purchasing, selling or chartering a yacht, please call +1(954)274-4435

TABLE OF CONTENTS

TABLE OF CONTENTS	2
SPECIFICATIONS	4
Overview	4
Basic Information	4
Dimensions	4
Speed, Capacities and Weight	4
Accommodations	4
Hull and Deck Information	5
Engine Information	5
DETAILED INFORMATION	6
Construction	6
Machinery	6
Electrical Systems	7
Plumbing Systems	8
Tankage	8
Navigation Equipment	9
Domestic Equipment	10
Accommodation	11
Deck Equipment	13
Broker's Comments	15
Manufacturer's Comments	15
Exclusions	15
Disclaimer	15
PHOTOS	16
CONTACTS	27
Contact details	27
Telephones	27
Office hours	27

Address

27

SPECIFICATIONS

Overview

The 575 Signature has a ballroom of an aft deck, with a great fly-bridge and palatial accommodation for six in her three cabins. This 1998 575 has a long extras list, is beautifully presented and deserves to be seen!

Basic Information

Category: Motor Yacht

Model Year: 1998

Year Built: 1998

Country: United Kingdom

Fly Bridge: Yes

Cockpit: Yes

Dimensions

LOA: 59' 4" (18.08m)

LWL: 49' 9" (15.16m)

Beam: 15' 0" (4.57m)

Min Draft: 5' 4" (1.63m)

Speed, Capacities and Weight

Cruise Speed: 14 Kts. (16 MPH)

Max Speed: 18 Kts. (21 MPH)

Displacement: 43999.85824996 Pounds

Water Capacity: 240.39656732 Gallons

Fuel Capacity: 1320.86026 Gallons

Accommodations

Total Cabins: 3

Total Berths: 6

Total Heads: 2

Hull and Deck Information

Hull Material: GRP

Deck Material: Teak

Hull Configuration: Semi-Displacement

Hull Designer: Tarquin/Trader

Engine Information

Engines: 2

Manufacturer: Caterpillar

Model: 3208 V8

Engine Type: Inboard

Fuel Type: Diesel

DETAILED INFORMATION

Construction

RCD Status: The yacht conforms with the essential safety requirements of Directive 94/25EC (Recreational Craft Directive) and is categorised A – “Ocean” (for 11 persons on board)

Part 1 British Registered.

Hull, Deck & Superstructure Construction:

- White GRP hull with blue pigmented topsides band, red style line and dark blue boot topping.
- Teak-laid decks to foredeck, side decks, aft deck, flybridge deck and bathing platform.
- White superstructure with blue and red style lines.
- White GRP flybridge overhang/hardtop over entire aft deck.
- Bathing platform moulded in white GRP.

Machinery

Engine & Gearboxes:

- Twin CATERPILLAR 3208 V8 turbo-charged diesel engines, rated 435HP @ 2800 RPM apiece.
- Caterpillar reduction gearboxes.

Maintenance & Performance:

- Engine hours – 1400/P & 1393/Stbd as of 01/05/2013.
- Cruising speed – approx 14 knots.
- Maximum speed – approx 18 knots.
- FloScan fuel monitors at lower helm.

Propulsion & Steering:

- Three-bladed bronze propellers.
- Hydraulic steering system.
- Thrustpower hydraulic bowthruster driven off starboard engine PTO (controls to both helms).

Electrical Systems

Voltage Systems:

- 12VDC/ domestic system with 220V ring main from generator and/or shorepower.

Battery Banks:

- 2 x 12V DC engine start batteries.
- 2 x 12V DC domestic service batteries .
- 1 x 12V generator start battery.
- Ships battery systems not in commission (unserviceable).

Battery Chargers:

- Mastervolt 12/50A Chargemaster smart battery charger.

Alternators:

- 2 x Caterpillar 12V alternators.

Generator:

- Onan 15kVa generator.
- Generator hours – 1484 as of 01/05/2013.

Shore Power:

- Ring main with shore power lead.

Plumbing Systems

Fresh Water & Water Heating System:

- Pressurized hot and cold water.
- Heating by Raritan 220V immersion and engine heat exchange.
- 5 litre and 8 litre accumulators.

Watermaker:

- Seafresh H2O4A watermaker – 72 litres per hour quoted capacity.

Bilge Pumps:

- 4 electric automatic bilge pumps with manual over-ride.

Grey & Black Water:

- Black water tank with deck pump-out facility and Tankwatch monitoring.

Tankage

Fuel:

- 5000L / 1100 US Gallon capacity in two tanks (extra capacity over standard).
- Racor primary filters with tank crossover.
- Starboard main fuel tank perforated and currently drained of fuel.

Fresh water:

- 910 L / 240 US Gallon capacity.

Blackwater holding tanks:

- GRP holding tank.

Navigation Equipment

At outside helm:

- Raymarine E80 Multifunction display linked to 2kW 18" closed array Raymarine radar.
- Autohelm ST80 Multiview instrument (Speed/Depth).
- Autohelm ST80 Masterview instrument.
- Autohelm Pilot.
- Autohelm MOB button.
- Autohelm digital Compass.
- Ritchie Angler magnetic compass.

At lower helm:

- Raymarine remote keypad linked to Digital Yacht flat-screen display.
- Autohelm ST80 Masterview instrument.
- Autohelm ST80 Multiview instrument (Speed/Depth).
- Raytheon ST60 digital Compass.
- Autohelm Wind instrument.
- Autohelm Navigator.
- Autohelm Autopilot.
- Clipper digital Navtex.
- Shipmate RS5800 GPS.
- Yeoman Plotter.

- Plastimo Horizon 135 Compass.

Communications Equipment:

- Simrad RS82 VHF DSC VHF (flybridge).
- Simrad RS82 VHF DSC VHF (lower helm).
- Raytheon 430 Loudhailer (lower helm).
- Raymarine 101E handheld VHF (and charging cradle to saloon).

Domestic Equipment

Galley:

- Dark black/brown patterned Corian counter-tops.
- Indesit washer/dryer.
- Hotpoint stainless steel electric oven .
- Neff 4-zone electric hob with powered extractor fan.
- Proline Combi microwave.
- Shoreline full-size fridge/freezer.
- Twin stainless steel sinks and mixer tap with rinsing head.
- Jabsco Aqua Filter to drinking water supply.

Heads/Showers:

- Ensuite/day heads forward with shower.
- Ensuite aft heads with shower/bath.

Heating & Ventilation:

- Diesel-fired cabin heating.
- Cruisair air-conditioning with controls to each cabin.

Entertainment:

- 22" Panasonic flat-screen with DVD player and Sony CD player/radio to forward double cabin.
- Bang & Olufsen system with full surround and TV to saloon.
- Simrad satellite receiver and Sky decoder box for saloon A/V.
- Bank & Olufsen system with surround and TV to aft master double cabin.
- MASH SLPD687 5-CD changer, Technics SUV620 Amplifier and Technics GT550 Tuner to aft dinette.

Lighting:

- Upgraded LED lighting throughout accommodation, engine room and aft deck areas.
- Reading lights to all cabins.

Accommodation

Summary of Accommodation:

- 6 berths in three cabins consisting of forward double, guest twin to port and double aft full-beam master cabin.
- Teak interior joinery with teak and holly flooring throughout accommodation.
- Removable oatmeal carpets to cabins and dinette areas.
- Solid buff-coloured headlinings throughout.

Description of layout from forwards:

- Access from starboard-side deck door and aft sliding door at aft starboard end of saloon. Raised saloon deck with seating to sides, navigators table and seat forward to port and main helm with bench seat forward to starboard. Access centrally forward through central corridor to twin guest cabin to port, day-head/shower access to starboard, access to forward double VIP cabin (with ensuite access to days heads/shower), and forward access to engine bay through locking door with clear panel under lifting forward companionway stairs. Aft accommodation through offset aft companionway with dinette to starboard, galley to port and aft double master

cabin leading aft. Aft engine bay access through locked door with clear panel under lifting aft companionway stairs.

Forward Cabin:

- Central double berth with 3 storage drawers beneath, hanging lockers to each side of foot of bed – one with drawer beneath – other with air-co controls and heating/air-co vents. LED lights and reading lights to head of bed, opening deck-hatch and 4 opening port-lights to hull sides. TV/DVD & Sony stereo with loudspeakers. Stowage cubbies around berth and access forward through louvred doors to chain locker. 4 power sockets.

Forward Heads:

- Accessed either by central corridor or door from forward VIP cabin. Green marbled surround to basin with HCG porcelain bowl and hot/cold mixer tap, shaver socket, Jabsco manual w.c., separate shower stall aft, with obscured glass door screen and mixer shower with fixed shower head. 2 opening port-lights and hatch access to lower helm electrics panel.

Port Guest Cabin:

- To port through door off central corridor, there are two single raised berths, split by a mirrored hanging locker with drawers beneath. The forward berth base forms a writing desk with three drawers, air-co controls and heater vent. 2 power points, 2 opening port-lights and a sliding hatch to ceiling for extra light from windscreens. 2 bookracks fitted with forward rack containing invoices, history, service and equipment manuals, etc.

Main Saloon:

- Forward end of saloon has the navigators table and a fitted chair to port, with the main helm and side deck access door to the starboard side. The pilot's bench (with drinks storage in a sliding cabinet) and sideboard aft of the navigators table separates the main saloon from the helm/chart area. Aft to port is a four-seater L-shaped sofa in cream leather, with an adjustable hi-lo varnished table to dining. To starboard is a three-seater bench sofa with stairs to aft deck through access door aft. To port in the sideboard is further storage and the satellite/A/V kit, with the Bang & Olufsen TV and control unit mounted on top. A U-Line icemaker is fitted and there is an Oregon Scientific digital weather station, air-co and heater controls, various handholds to ceiling and furniture, with Plastimo brass clock and barometer set with Liverpool & Glasgow inclinometer fixed on the aft bulkhead. Many power-points, with cream curtains for aft windows and screen covers for the windscreens. EPIRB and First Aid kit fitted to aft access stairs.

Galley:

- The aft accommodation is accessed down a ladder, with the galley set to port, and a facing dinette to starboard. The galley is U-shaped with a teak and holly sole, with fitted appliances and dark patterned Corian worktops. Plentiful high-level and low-level cupboards, drawers and lockers, with 6 power points and two opening port-lights.

Dinette:

- Located at base of stairs to starboard, a large varnished adjustable table with hi-lo mechanism is fitted, with a three-seater L-shaped sofa trimmed in floral fabric, with fitted book rack and cupboard stowage behind. Two opening port-lights and heater control and vent are located next to the dinette A/V equipment.

Owners Cabin:

- A large centre-line walk-around double berth with night-stands to each side, reading lights, two opening port-lights and two large opening transom hatches. Hanging lockers, stowage lockers and cupboards surround the cabin, with a dressing table/vanity area to starboard with swing-out stool. Power points, air-co controls and heater outlet, with LED down-lights, Sony CD/stereo and Bang & Olufsen TV with sculpted speakers.

After Ensuite Heads/Shower:

- Access through forward port door from aft owners cabin, teak and holly floor with moulded white cabinetry with cherry trim, green marbled basin surround, electric Jabsco w.c., porcelain basin and screened shower/bath at forward end with mixer tap/shower. Opening port-light and shaver socket.

Deck Equipment

General:

- Deckwash to bows.
- Large GRP flybridge over-hang to shade aft deck, inset with down lights, liferaft stowage on top.
- Curved stairs aft (with safety gate) to port leading down to bathing platform area.

Anchoring & Mooring Equipment:

- Lofrans electric windlass.
- Plough anchor and chain.
- Powered aft mooring winches.
- Three sets cleats with fairleads per gunwhale (large bits to fore and aft decks).
- Side access gates to guardrails and docking ladder.

Covers, Canvas & Cushions:

- Blue canvas curtains to enclose aft deck.
- Blue canvas flybridge tonneau cover, white canvas windscreen cover.
- Stainless steel bimini frame with canvas bimini shade.
- White vinyl deck cushions with blue piping for all outside seating areas.

Tender & Outboard:

- Quicksilver 340 RIB tender.
- Suzuki DF6 outboard engine in deck bracket.
- Tender storage chocks to aft bathing platform with stainless steel hydraulic passarelle/dinghy lift.

Safety Equipment:

- Plastimo 6-man canister liferaft mounted in bracket on flybridge overhang (service dates unverified).
- 3 liferings.
- EPIRB.
- Searchlight .

Fire-fighting equipment:

- 3 x 2kg automatic dry powder extinguishers to engine space (service dates unverified).

Various dry powder and foam extinguishers to accommodation.

Broker's Comments

The 575 is a mighty piece of construction with serious sea-going intent. Her semi-displacement hull form means that she is comfortable through conditions which will leave a full-planing hull wanting, and she has massive load-carrying ability combined with truly spacious accommodation. Her interior has vast volumes for storage, which is beautifully put together by the experienced shipwrights of the Kha Shing yard, with three good-sized cabins and a fantastic main saloon. Her covered aft decks provide shade from the sun, and can be completely enclosed when the climate is not so kind.

This example has many updates, including Bang & Olufsen systems, a Digital Yacht navigation package, low-draw LED lighting system, and is presented in a clean and tidy condition with all manuals available.

Manufacturer's Comments

The combination of the sea stair arrangement and huge aft deck make a 575 Signature a great way to enjoy being at sea. They really suit couples who do a lot of extended voyages.

Exclusions

Owner's personal belongings.

Disclaimer

The Company offers the details of this vessel or yacht in good faith but cannot guarantee or warrant the accuracy of this information nor warrant the condition of the vessel. A buyer should instruct his representatives, agents, or his surveyors, to investigate such details as the buyer desires validated. This vessel or yacht is offered subject to prior sale, price change, or withdrawal without notice.

PHOTOS

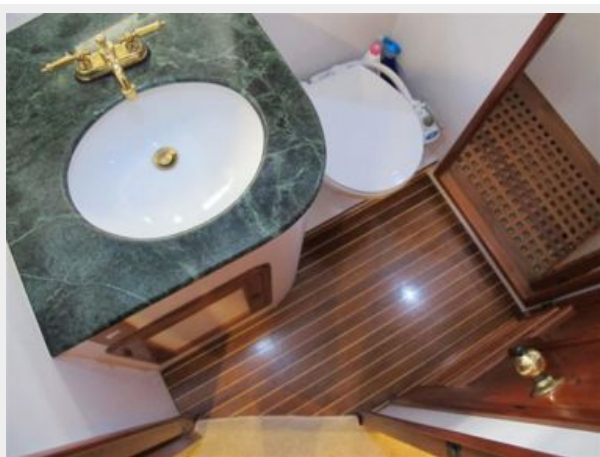





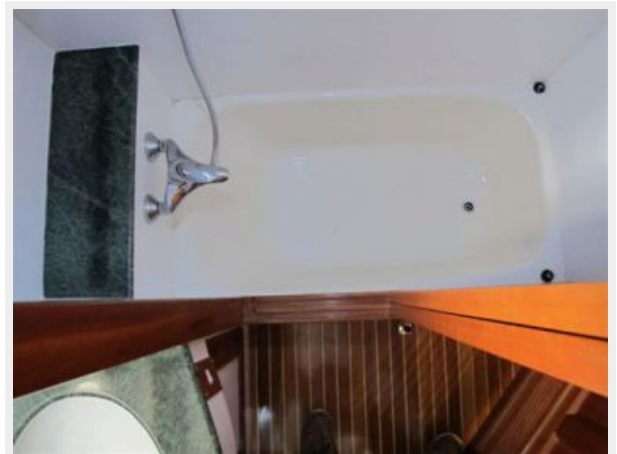



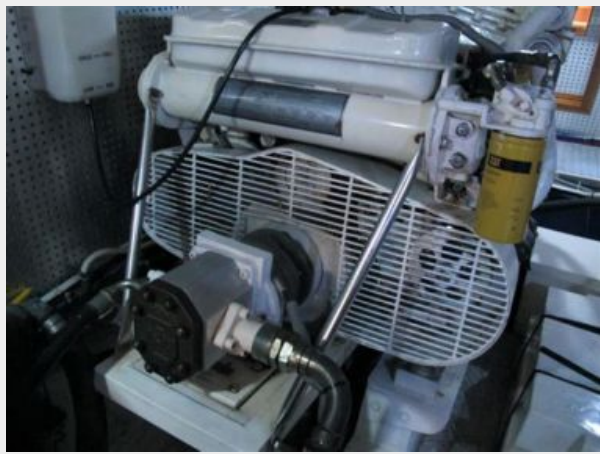

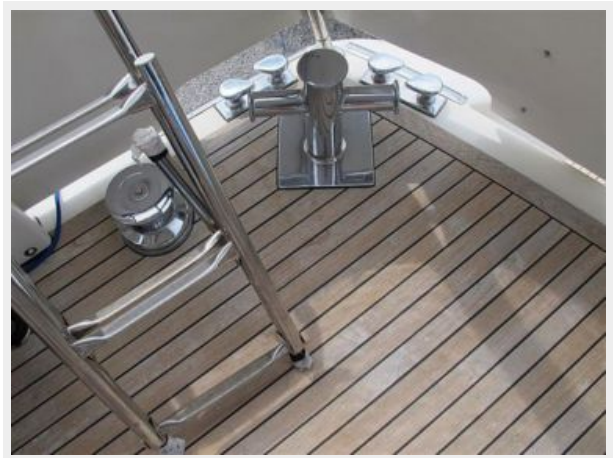

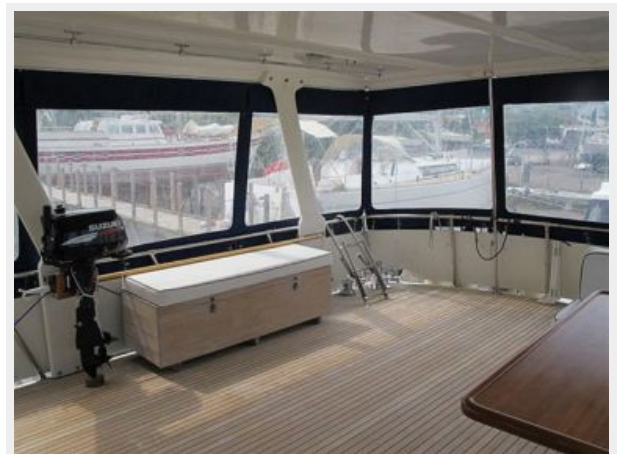



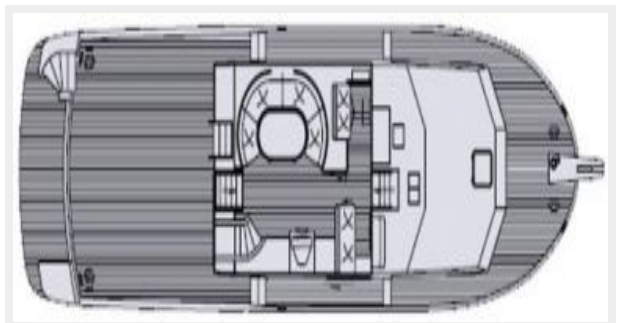
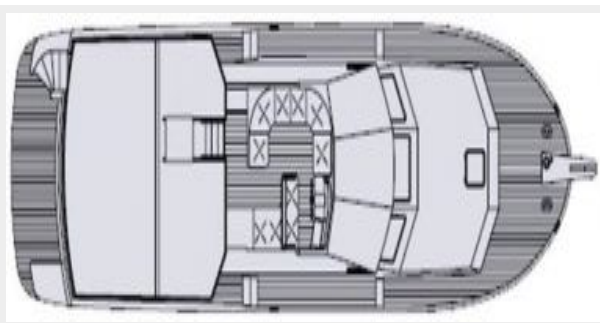

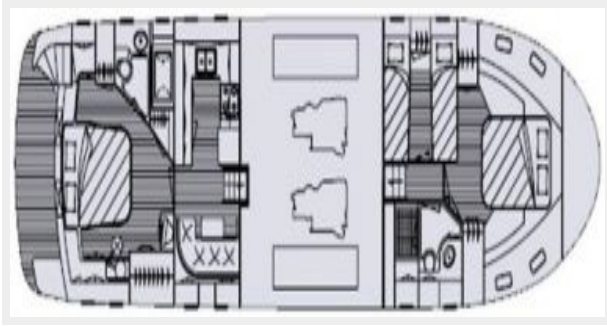

CONTACTS

Andrey Shestakov, leading yacht broker of the sales department of Shestakov Yacht Sales Inc. Shestakov Yacht Sales Inc., the official representative of the Miami/Fort Lauderdale FL headquarters.

Contact details

Email: andrey@shestakovyachtsales.com

Web: shestakovyachtsales.com/en/

Telephones

USA: +1(954)274-4435

Office hours

Monday – Saturday: **9:00 - 21:00** EDT

Sunday: **closed**

Address



Harbour Towne Marina, 850 NE 3rd St,
STE 213, Dania, FL 33004